

RLA 2 PART Cementitious Waterproofing membrane



DESCRIPTION:

RLA 2 PART is a cementitious, two-part waterproofing membrane. RLA 2 PART is based on high alumina and fast-setting cement. It is mixed with high solids water resistant pure acrylic. RLA 2 PART combines the quick drying and excellent adhesion characteristics of traditional 2-part membranes with the superb toughness, elongation, and flexibility of modern acrylic membranes.

RLA 2 PART has excellent adhesion to concrete, cement screeds and most F/C sheet. It is used with RLA elastic waterproof tape for maximum performance and ease of use.

RECOMMENDED USE:

- Concrete after curing for 28 days.
- Masonry / render after curing at least seven days.
- Cement sheeting / underlay / external weatherboard / blue board.
- Pre-cast concrete once the release agent has been removed/ dissipated.
- Wet area plasterboard / Villaboard.
- Brickwork, Hebel (aggregate block)
- RLA 2 PART is suitable for most swimming pools of concrete construction if it has been rendered and then primed with [RLA MOISTURE SEAL](#).

SURFACE PREPARATION:

Concrete should have a wood-trowelled finish. Surfaces should be clean, dry, and free of grease, dirt and curing compounds. All building materials must be fixed by the manufacturer's instructions regarding external areas and tiling. Concrete should cure for at least 28 days, and cement screeds should be cured for seven days before waterproofing. Dense, steel-trowelled, or highly finished concrete must be abraded to yield a rough finish. Sheet joints and cracks larger than 1 mm should be filled with [RLA FILLET AND JOINT SEAL](#), then covered with RLA WATERPROOFING BANDAGE.

Also, use RLA Moisture Seal on concrete surfaces that are less than four weeks old or have been inundated with water and cannot be adequately dried.

MIXING:

Add approx.—8 litres of liquid to a 20L bucket. While mixing with a power mixer, add one of the 10 kg bags of powder and continue mixing until a thick, smooth paste is achieved.

When the mixture is lump free, add another 2 litres of liquid and continue mixing until homogeneous.

Allow standing for 5 minutes.

Remix for a few seconds, and the product is ready to apply.

Smaller quantities can be mixed, if necessary, using the same ratios.

Remix every 20 to 30 minutes if required. If storing for a short time, place a lid on the bucket to reduce skinning and then remix when ready to use.

Only use a product that has been mixed and left standing for 2 hours or has become very thick.

APPLICATION:

Dilute some of the mixture 10-20% with water and prime the surface with this mixture.

Apply RLA 2 PART waterproofing using a brush roller or airless spray at a spreading rate of about 1.2m² per litre of product.

Allow 4-8 hours to dry, then apply a second coat. The average film build should be 1.2mm dry film thickness.

The minimum film build should be 1.0mm.

Ensure that the membrane continues up walls at least 150mm (and under flashing) as well as up and over any parapet walls and into any wastes.

Allow the final coat to dry for at least 24 hours before tiling (longer in cool climates). In pools, allow curing for a minimum of 7 days.

Please get in touch with the RLA Technical department for further details.

APPLICATION:

Continued:

Take special care to use RLA WATERPROOFING BANDAGE with wall floor junctions. (See Fig 1)

Where expansion joints or control joints are built into the floor or wall (10mm or less), these must be bridged with RLA WATERPROOFING BANDAGE. (See Fig 3) and then brought through to the tiling. RLA 2 PART can be used underneath or above cement screeds before tiling.

Use RLA WATERPROOFING BANDAGE to reinforce the membrane at wall/floor junctions, Sheet joints, expansion joints and over-crack repairs.

For cracks more significant than 3mm, consult the RLA Technical Centre.

Where the RLA WATERPROOFING BANDAGE must be joined, overlap the strips by at least 100mm. Use prefabricated corner tape at internal corners or external corners or, if necessary, make the corner by cutting and folding the tape.

Ensure any cut corners are well sealed with 2 PART.

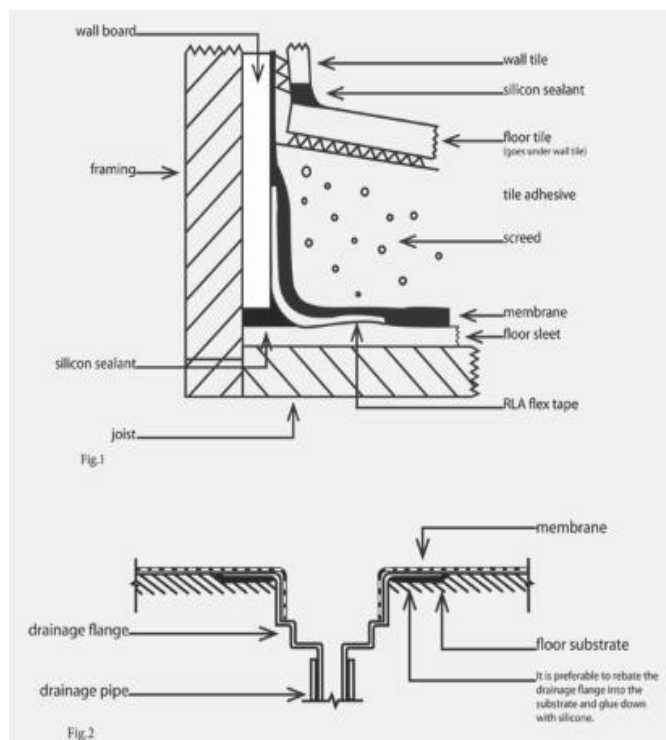

APPLICATION:

Continued:

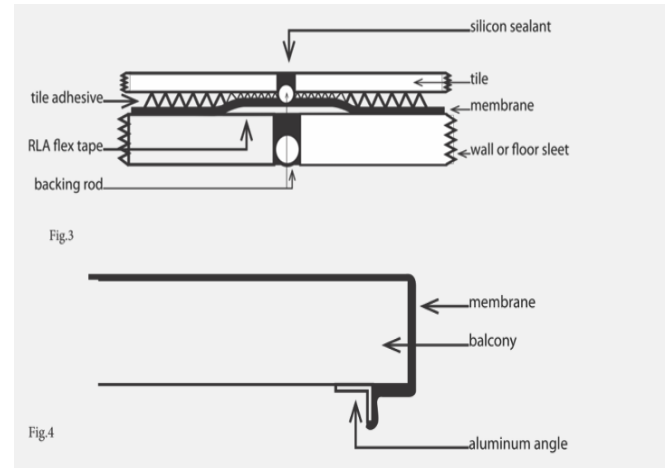

APPLICATION RATES:

FLOORS & WALLS:

Apply a minimum of 2 coats at a total rate of 1.5 litres/m² to achieve a dry film thickness (DFT) of 1mm.

WPU	WET FILM	DRY FILM	TOTAL DFT
<u>1 COAT</u>	<u>0.75mm</u>	<u>0.50mm</u>	<u>0.50mm</u>
<u>2 COATS</u>	<u>0.75mm</u>	<u>0.50mm</u>	<u>1mm-1.2mm</u>

DRYING TIMES

Depending on ambient conditions, allow 4-8 hours of drying time between coats.

A longer curing time will be required in cooler temperatures and high humidity to achieve a cured film between coats. Allow 24 hrs to dry before tiling. Allow longer in adverse conditions.

BOND BREAKER:

Bond breakers are required at all wall/floor, hob/wall, junctions, and all movement joints (wall/wall) where the membrane is bonded to the substrate.

The Bond breaker shall be of the type compatible with Class II flexibility membranes.

Joint Seal, RLA WATERPROOFING BANDAGE, or an appropriate proprietary bond breaker tape specified under membrane application should be used.

If any cracks in the substrate are evident, grind out the crack to a width of at least 6mm, fill it with a neutral cure silicone, and allow it to cure.

Apply RLA Fillet joint sealant and waterproof bandage or bond breaker tape over the entire crack to isolate it from the membrane.

If applying membrane over Hardie flooring systems, follow Hardie's recommendations for fixing and sealing expansion joints.

Apply RLA Fillet joint sealant and waterproof bandage to all drainage outlets, flanges, water stops etc.

Dedicated Expansion Joints must be isolated from the membrane using RLA WATERPROOFING -BANDAGE, ensuring at least 12mm on either side of the crack and covering the entire length and width of the joint.

CLEAN UP:

Clean tools immediately after use with warm soapy water while the membrane is still wet.

SHELF LIFE / STORAGE:

12 months when stored in original unopened packaging. To be stored in a dry area off the ground.

PRODUCT DATA:

Appearance	OFF WHITE
Packaging	2 x 10Kg powder & 20 litres of Liquid
Mixing Ratio	1:1
S.G of mixed product	1.40 approx.
Classification	Class II
Total Solids Content	80%
Coverage	23m² per 40Kg Kit
Tensile Strength	1.9 Mpa
Final Drying Time	24 hr @ 23°C & 50% RH

LIMITATIONS:

- Is not designed to stop a hydrostatic head of water pressure. Use RLA Moisture Seal to seal concrete first.
- Must not be used over damp, wet, or contaminated substrates
- Protect uncured waterproofing from rain or leaking water.
- Must not be applied externally if it is raining or rain is imminent.
- Must not be used as a wearing surface for heavy foot or vehicle traffic
- Should not be applied where the surface temperature is below 10°C or greater than 40°C
- Make sure the membrane has an even thickness of 1.0 to 1.5mm when dry.
- For more complex balcony structures, consult AS4654.2 Waterproofing Exterior for details and drawings.
- For swimming pools, more detailed information can be sought from the RLA Technical Centre.
- For step-down, frameless showers & other complex bathrooms, consult AS 3740:2021.

Please get in touch with the RLA Technical department for further details.

SAFETY & HANDLING:

- Do not breathe dust; wear suitable respiratory protection.
- Use in well-ventilated areas.
- Avoid contact with skin and eyes.
- Wear eye protection and suitable gloves and clothing.
- Do not eat, drink, or smoke while using this product.
- Take off contaminated clothing and wash it before reuse.

The Safety Data Sheet is available upon request.

FIRST AID:

- If poisoning occurs, contact a doctor or the Poisons Information Centre.
- If swallowed, DO NOT induce vomiting; give a glass of water and immediately call the Poisons Information Centre and a doctor.
- For advice or if you feel unwell, contact a Poisons Information Centre: Australia ph. 131126, New Zealand ph. 0800 764 766 or a doctor at once.
- If on SKIN, remove all contaminated clothing immediately and wash skin with soap and water.
- If in EYES, rinse carefully with water for several minutes. Remove contact lenses; if present, then continue rinsing.
- If eye irritation persists, get medical advice/attention.
- If inhaled, remove them to fresh air, and keep them at rest in a position comfortable for breathing.

WARRANTY STATEMENT:

RLA Polymers guarantees this product against manufacturing defects and guarantees it to be manufactured to our published specifications.

We certify that this product is suitable for use when fully cured and will perform as described in our technical data sheet or other published materials.

RLA Polymers will replace the product free of charge when purchased from any legally verifiable source and where a product is proven to have been stored, handled, and install according to instructions published on our packaging and within the stated shelf life. The Installation of all materials must be carried out per the relevant Australian Standards.

Warranty doesn't apply if damage, loss, failure to follow instructions, or other circumstances are out of our control.

Sufficient time and access to investigate any complaint must be accorded to RLA Polymers.

The consumer is responsible for any expenses incurred in making a claim.

A claim form can be requested by:

PHONE: 1800 242 931

EMAIL: info@rlapolymers.com.au

MAIL: 215 Colchester Road Kilsyth Victoria 3137 (Attention Customer Service)

WEBSITE: www.rlapolymers.com.au

AUSTRALIAN CONSUMER LAW:

Our goods come with guarantees that cannot be excluded under the Australian Consumer Law. You are entitled to a replacement or refund for a major failure and compensation for any other reasonably foreseeable loss or damage. You are also entitled to have the goods repaired or replaced if the goods fail to be of acceptable quality, and the failure does not amount to a major failure. The benefits under our warranty are in addition to other rights and remedies available to the consumer under the law in relation to the goods and services to which the warranty relates.

DISCLAIMER:

All statements and technical information contained herein are based on tests we believe to be reliable, but the accuracy thereof is not guaranteed.

Users assume all risk and liability resulting from the use of the product and must confirm the suitability thereof by their own tests. Conditions of Sale contain a limited warranty against manufacturing defects.